

How to easily print photos for competition entry

Below follows a brief overview of my method for easy print competition entry, using a good quality online printing company, and re-using mounts. Feel free to contact me with any questions or suggestions on alexrobinson202@gmail.com.

0. Photo Selection

Half the job is choosing the right photos to print – if in doubt print more than you need!

1. Screen Calibration

High-end laptop / MacBook / iMac (using inbuilt screen):
Probably don't need to worry about it! But set screen brightness to ~2/3rds to better match the brightness of prints.

Lower-end laptop or external monitor: Either try first set of prints and see if you're happy, or borrow the club's Spyder to calibrate your system.



2. Paper Size

Aim is to choose a paper size that works well for the common mount size of 40x50cm, is readily available, and allows for various aspect ratios. Print on same size paper for all aspect ratios for ease.

10x15" (25x38cm) is a sensible option, giving sensible border width at all aspect ratios.

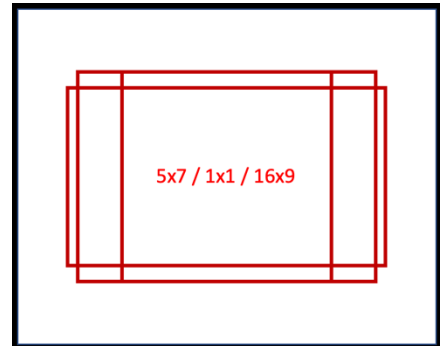

3. Commercial Printing Options

'Highstreet' printers e.g. Snappy Snaps: generally quite expensive but normally good quality

'Well known' online brands e.g. Vistaprint /PhotoBox etc: very cheap but mixed quality

'Professional' online sites: my choice is DS Colour Labs, good range of paper options, good quality and well priced. Others also available e.g. SimLab & The Print Space

4. Paper Calibration

DS Colour Labs offer paper calibration files for their standard paper options (for fancy papers they will add it themselves). Useful 'Preparing your Files' section on website with calibrations, also confirms to use sRGB and 300dpi.

5. Lightroom Virtual Copies

Often would increase exposure by ~1/3rd stop for printing, maybe some other small changes compared to screen viewing. Useful to make 'Virtual Copy' in Lightroom. Pre-select images for printing, create new Collection, and check 'Selected Images' and 'Virtual Copy' options.

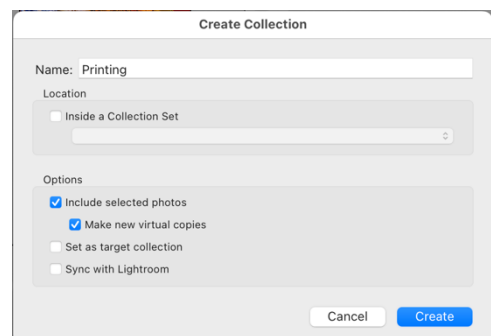

6. Lightroom Print Module

Not just used for printing at home! Aim is to create a set of JPEG files of the correct size. As we are printing different aspect ratios on the same paper, need to fill the border in with black / white. Can also add paper calibration if desired.

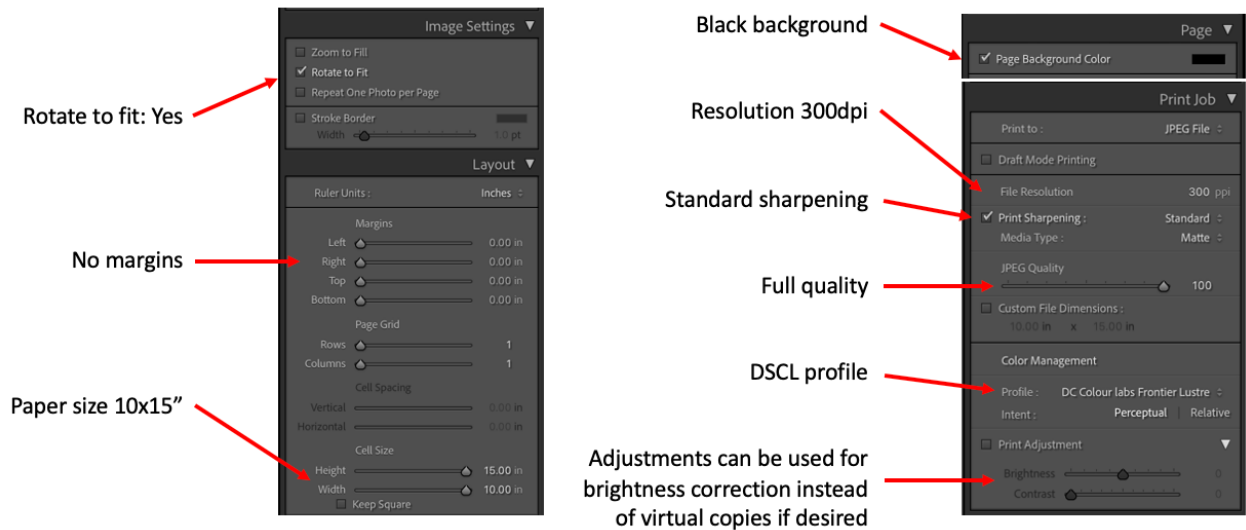

7. Ordering Process

www.dscourlabs.co.uk

Choose paper size (10x15") & type – Lustre / Gloss (your choice!)

8. Mounts

Many online suppliers offer off-the-shelf and custom mounts, I have used Brampton Framing, but many other options. Need enough mounts for one competition, all 40x50cm size, various apertures:

2x 10x14" white

1x 10x14" black

1x 10x10" white

1x 10x10" black

1x 7.8x15" white

1x 7.8x15" black

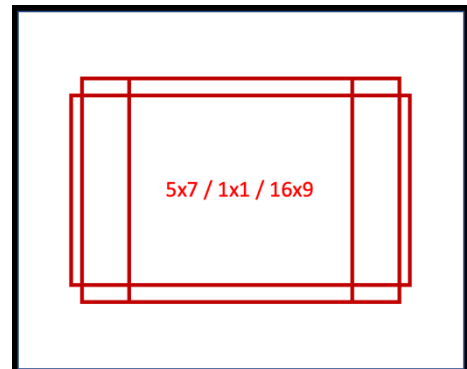

9. Total Costs

Prints:

£1 each plus £5 postage

Try to order in batches of >10, assume 2 orders per season

Mounts:

£8 each, 7 off, = £56

Re-use for 3 seasons (5 competitions per season)

Total: ~£10 per competition